











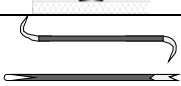

# **HOTDIVE Repair Guide S1 First Stage**



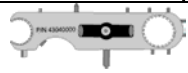

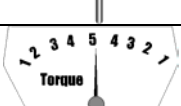

**USE THIS GUIDE AS A REFERENCE WHEN  
SERVICING THE S1 FIRST STAGE**

***TOOLS NEEDED FOR REPAIR OF S1 FIRST STAGE***











Quantity	Part Number	Description	
1		Ratchet	
1	S10-105	1" Yoke Nut Socket	
1	S10-101	Standard piston first stage seat removal tool.	
1 set	S10-102	Brass o'ring picks	
1 tube	S10CL01	Christo-Lube	
1	S10-103	Counter Mat	
1	S10LS02	Lubricant syringe	
1	S10-104	Universal Tool	
1	S10-105	First Stage Handle	
1		Torque Wrench	
1		Hex Key Set	
1		Crescent wrench	
1	S12-001	Pneumatic Adjusting tool	
1	S10-106	Blow Gun/Air Nozzle	

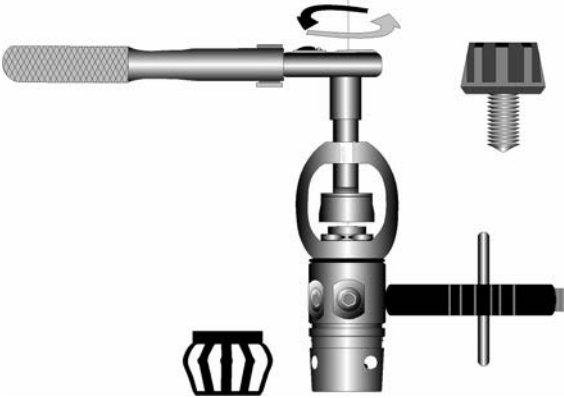

**ICON LEGEND**

	Inspect carefully, replace if needed
	Lubricate properly
	Replace annually
	Dynamic o'ring, lubricate properly
	No tools needed for this step



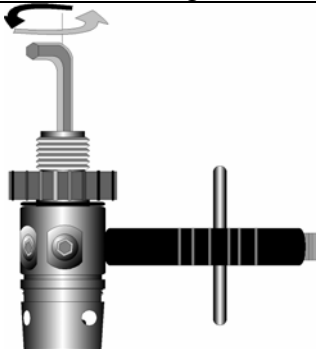

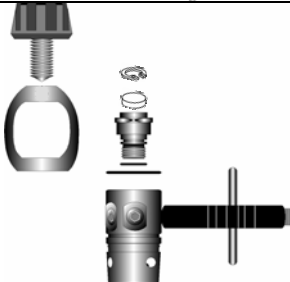

## HOTDIVE S1 First Stage

			
<p>Remove all hoses.</p> <p>Thread the first stage handle into the high-pressure port as shown.</p> <p>Use the ratchet and yoke nut socket to remove the yoke nut from the first stage.</p> <p>Remove the cap cover.</p>			

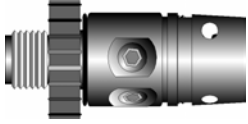
		 <p>5/32"</p>
<p>Remove all hoses.</p> <p>Thread the first stage handle into the high-pressure port as shown.</p> <p>Loosen the filter retainer using a 5/32" hex wrench.</p>	<p>For DIN Regulators</p> 	

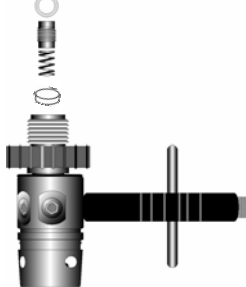
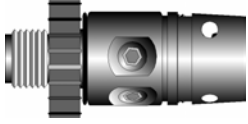

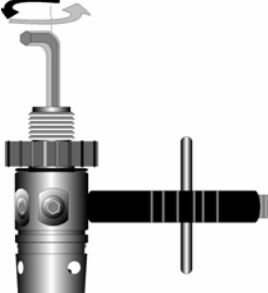
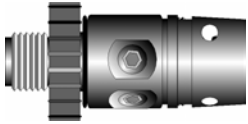
	
<p>Remove the yoke nut and yoke from the first stage body.</p> <p>Loosen the circlip and remove the filter.</p> <p>Remove the yoke nut o'ring.</p>	

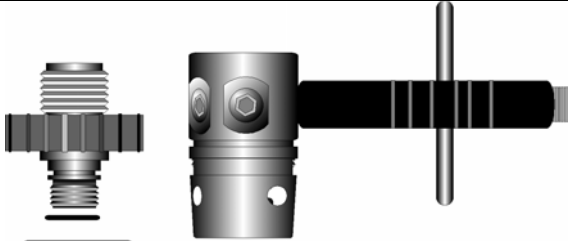
### HOTDIVE S1 First Stage

		
<p>Remove the filter retainer, spring, filter, DIN adapter and o'ring.</p>	<p>For DIN Regulators</p> 	
		 6mm
<p>Loosen the DIN fitting using a 6mm hex wrench.</p>	<p>For DIN Regulators</p> 	
		 6mm
<p>Remove the DIN fitting from the regulator body.</p> <p>Remove the DIN fitting o'ring.</p>	<p>For DIN Regulators</p> 	

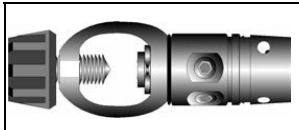
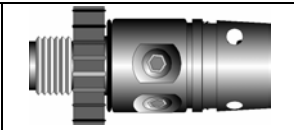
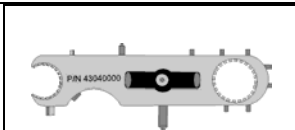
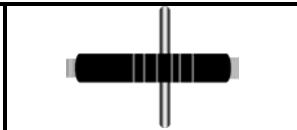
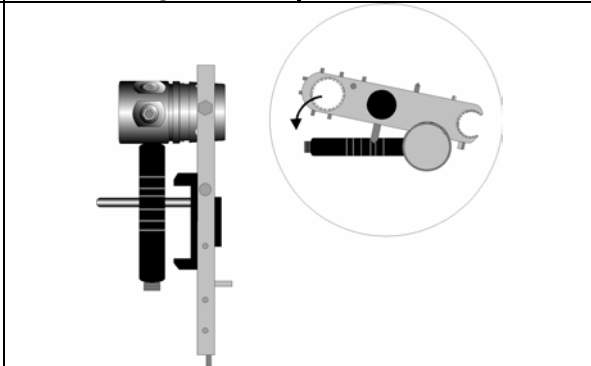

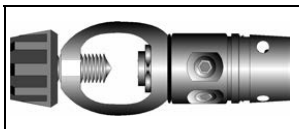
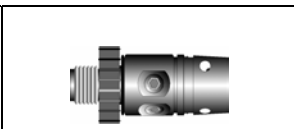

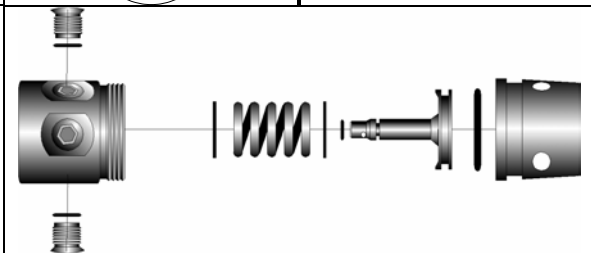

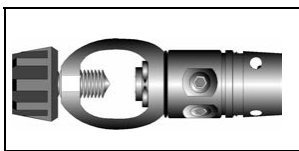
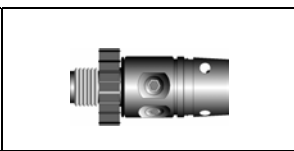
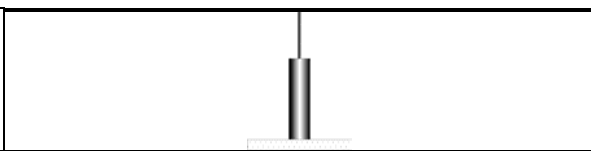
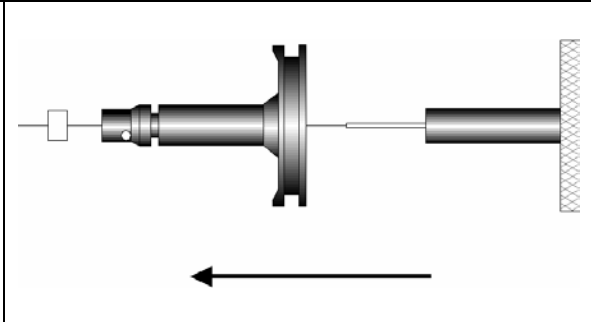

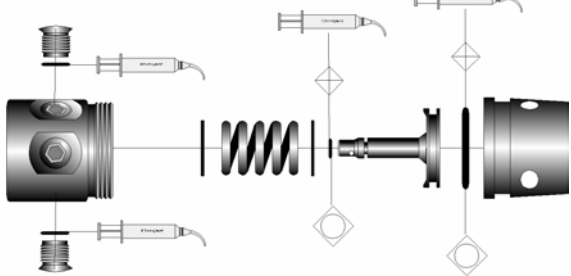

## HOTDIVE S1 First Stage

			
<p>Loosen the regulator cap from the regulator body using the universal tool and first stage handle.</p>			



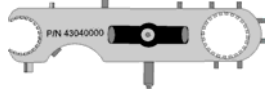
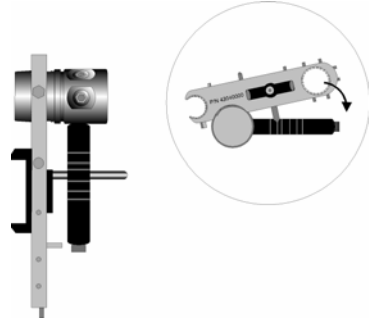



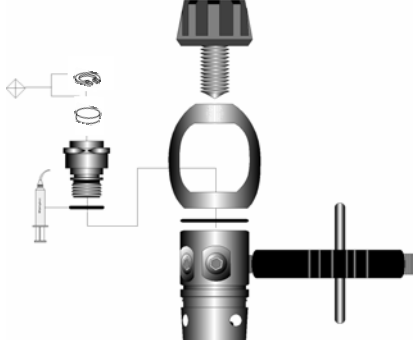

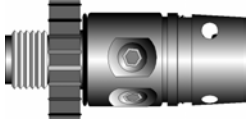

			<p>No tools needed this step</p>
<p>Separate the regulator body and cap. Carefully remove the piston assembly, spring and shims.</p>			

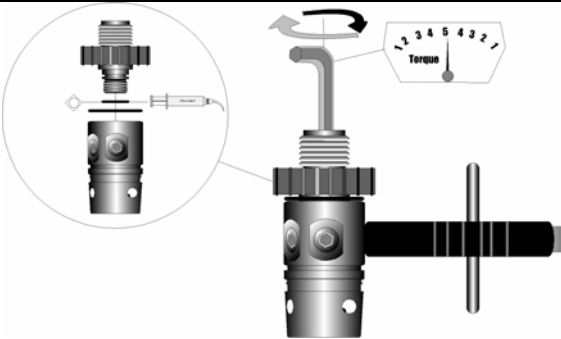
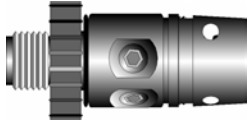
			
<p>Remove the high-pressure seat from the piston using the seat removal tool.</p>			

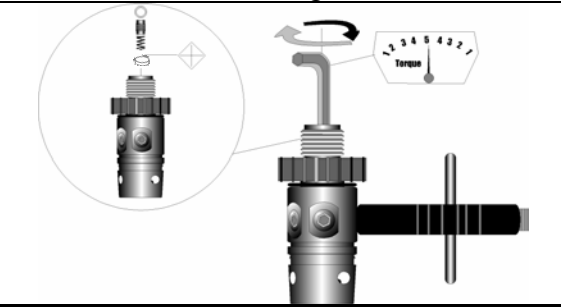

## HOTDIVE S1 First Stage

			
<p>Replace the piston head and piston stem o'rings. Lubricate these o'rings to dynamic specification.</p> <p>Insert the spring, seat assembly and shims into the regulator cap.</p>			
			
<p>Use the universal tool and first stage handle to tighten the regulator cap to the regulator body.</p>			
			
<p>Replace the filter and star retainer. Lubricate the yoke nut o'ring.</p> <p>Reassemble the yoke to the regulator body.</p>			

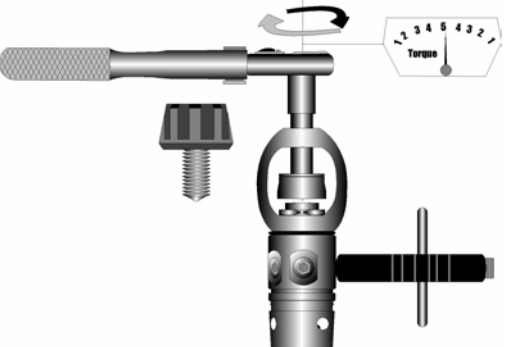
## HOTDIVE S1 First Stage

		 6mm		
<p>Inspect and lubricate the DIN fitting-to-body o'ring.</p> <p>Attach the DIN fitting to the regulator body.</p> <p>Torque the DIN fitting to 266 in-lbs/30 N-m.</p>	<p>For DIN Regulators</p> 			
		 5/32"		
<p>Insert a new filter, the spring, the filter retainer, and o'ring.</p> <p>Use a 5/32" hex wrench to tighten.</p> <p>Torque to 35 in-lbs/4 N-m.</p>	<p>For DIN Regulators</p> 			
		 Torque		
<p>Tighten the yoke nut using the ratchet wrench and yoke nut socket.</p> <p>Torque the yoke nut to 266 in-lbs/30 N-m.</p>				

## HOTDIVE S1 First Stage

		
<p>Check the intermediate pressure using the pneumatic adjusting tool.</p> <p>Intermediate pressure should be 125psi – 145psi at 3000psi and 300psi supply pressure.</p>		